

POINTAX 6000M

Point Recorder

3-348-819-03
2/8.18

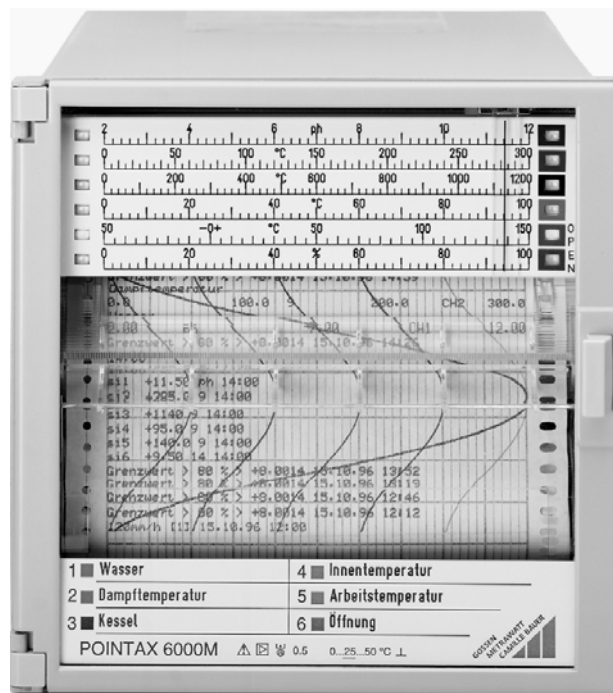

Contents

	Page
1 Installation and startup	3
1.1 Scope of delivery	3
1.2 Mounting site	3
1.3 Installation	3
1.4 Connection	4
1.5 Placing the recording chart	5
1.6 Placing the color head	6
1.7 Switching the recorder on	6
1.8 Positioning the recording chart	6
2 Operation	7
2.1 Removing the recording chart	7
2.2 Removing the recording chart from the take-up reel (see Figure 12)	7
2.3 Changing the chart speed	7
2.4 Standby function	7
2.5 Measured value display	7
2.6 Balancing function	8
2.7 End-of-chart signalling	8
3 Parameterizing	9
4 Reconfiguration	9
4.1 Firmware update	9
4.2 Replacing scales	9
4.3 Replacing the label for measuring points (see Figure 16 and Figure 17)	10
4.4 Replacing the case doors	10
5 Maintenance	11
5.1 Fuse replacement	11
6 Technical data	12
7 Packing	15
8 Returns and Environmentally Sound Disposal	15
9 Repair and Replacement Parts Service Calibration Center* and Rental Instrument Service	15
10 Product Support	15

Reference symbols in the text

<Key>	Designation of the keys in the display and control panel
{Display}	Non-flashing presentation on the display
{Display}	Flashing presentation on the display

The information "right", "left" or "top", "bottom" – unless otherwise stated – is on the understanding that the viewer looks at the front.

Supplementary documents

Parameterizing instructions POINTAX 6000M (Scale version)
Interface description POINTAX 6000M
(can be downloaded from our website)

Important information for your safety! It must absolutely be read and followed!

A condition of correct and safe operation of the point recorder POINTAX 6000M is that it is transported and stored in a suitable manner, competently installed and started as well as operated correctly and serviced carefully.

Only those persons must work on the recorder who are familiar with installation, startup, operation and servicing of comparable equipment and who have the qualification required for their work.

The contents of these operating instructions and the safety notes affixed to the unit are to be observed.

The regulations, standards and directives mentioned in these operating instructions are for the Federal Republic of Germany. When using the recorder in other countries, relevant national rules must be followed.

The recorder is constructed and tested in accordance with DIN EN 61010-1 "Safety requirements for electronic measuring, open-loop control, closed-loop control and laboratory instruments", it left the factory in safe and proper condition. To maintain this condition and to ensure safe operation, the safety notes in these operating instructions with the heading "Caution" must be followed. Otherwise, persons could be endangered and the unit itself as well as other equipment and facilities could be damaged.

If the information contained in these operating instructions should not be sufficient in certain cases, our product support (see page 15) will be glad to provide further information.

Application and brief description

The POINTAX 6000M is a microprocessor-controlled point recorder. It is supplied in two different versions:

- scale version with 1 to 6 scale divisions,
- display version (no more available)

The recorder is connected to transducers and/or directly to thermocouples or resistance thermometers. The measuring channels are electrically isolated and earth-free. The recorder is matched to the measuring task via the software by means of

- keys of the display and operating panel
- PC and parameterizing program PARATOOL P6000M via the RS 485 interface.

Standard temperature sensor curves are stored in the firmware of the recorder and linearized with high accuracy. Supplementary functions like text print, balancing function and event marker increase the information content of the print-out process quantity. Alarm signalling and remote control make the recorder a device to be used in a wide range of applications. The standby function makes triggered recording operation possible.

1 Installation and startup

1.1 Scope of delivery (see Figure 1)

The point recorder comes with:

- operating instructions
- 2 fasteners **Be**
- 1 color head **Fk**

- 1 package fanfold chart **Fp** or 1 chart roll **Sr**
- Depending on the order, the respective number of screw-plug terminals **Sk**, one zener diode combination per measuring system, 9-pole sub D plug and reading rulers.

- Be** Fastener
- Fk** Color head
- Fp** Fanfold chart
- Sk** Screw-plug terminals
- Sr** Chart roll

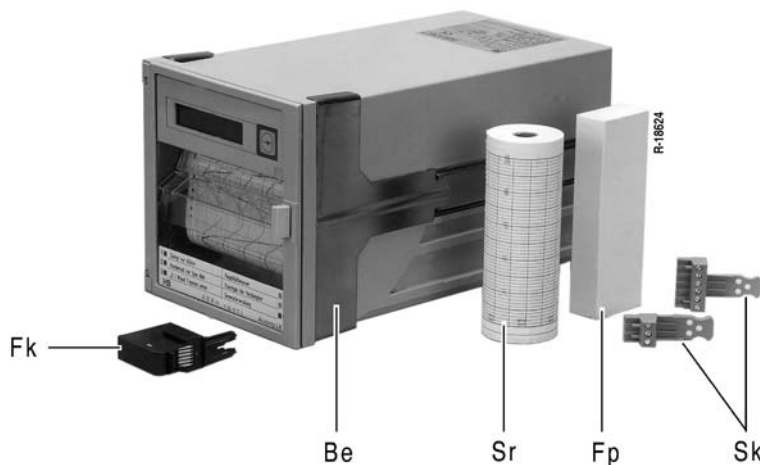

Figure 1 Scope of delivery of the POINTAX 6000M

1.2 Mounting site

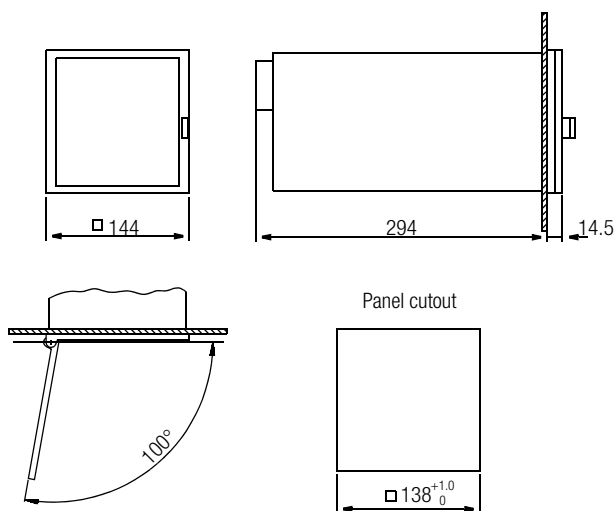

Figure 2 Dimensional drawing POINTAX 6000M (dimensions in mm)

Position of use	Inclin. to the side $-30^\circ \dots 0 \dots +30^\circ$
Inclination to the rear	20°
Inclination to the front	20°
Ambient temperature	$0 \dots 50^\circ\text{C}$
Relative humidity	$\leq 75\%$ annual average, max. 85 %, prevent dewing!

Note

The fasteners **Be** are suitable for side-by-side mounting in horizontal or vertical direction.

3. After aligning, equally tighten the fasteners.

Installation in grid frames

1. Fasten 4 centering angle brackets (Ordering number A416A) on the grid frame.
2. Push the fasteners **Be** in the guiding grooves at the side of the case (see Figure 3).
3. After aligning, equally tighten the fasteners.



Figure 3 Inserting the fasteners

1.3 Installation (see Figure 2 and Figure 3)

Installation in switchboards

1. Insert the recorder from the front into the switchboard.
2. Push the fasteners **Be** in the guiding grooves at the side of the case (see Figure 3).

1.4 Connection

⚠ Caution

The connection between the protective conductor connection and a protective conductor must be made prior to all other connections.

The unit can become dangerous when the protective conductor is interrupted inside or outside the unit or when the protective conductor connection is undone.

The recorder must only be operated in installed condition.

A line connection switch of sufficient switching capacity, which permits all-pole disconnection of the recorder from the line, must be provided within reach of the mounting site. It must not annul the protective effect of the protective conductor.

The nominal current of the overcurrent protective equipment on the installation side must not exceed 16 A.

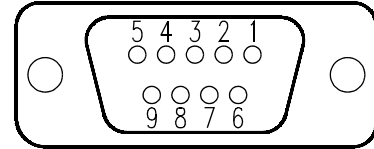
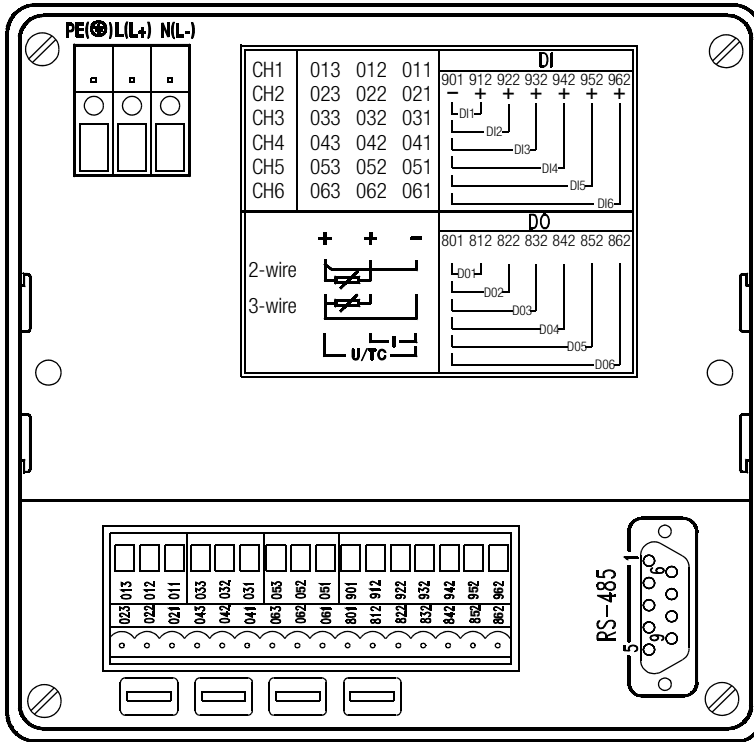

RS 485 interface

- Pin 1: Screen
- Pin 3: RXD (+)
- Pin 5: Gnd (reference potential)
- Pin 6: +5 V
- Pin 8: RXD (-)
- Pin 9: I/O converter (-)

For bus operation:

The voltage +5 V at Pin 6 is required when the POINTAX 6000M is used as bus terminal.

The screen is put on a plug-in knife at the recorder case.

Binary inputs

Binary input = depending on the parameterization for speed change, standby, event marker initiation, text print

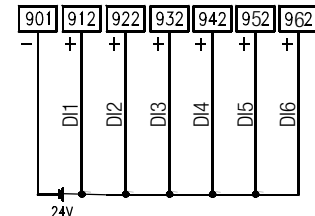
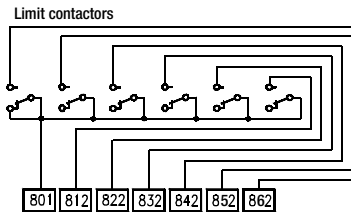
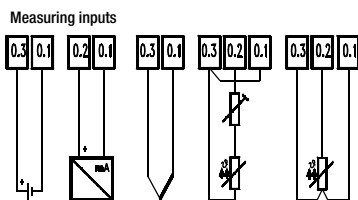

Figure 4 Rear panel and wiring diagrams

Connecting measuring signals

- Fix signal cables max. cross section $2 \times 1 \text{ mm}^2$ in the screw-plug terminals.

Connecting power supply

- Fix power supply cables max. cross section $1 \times 4 \text{ mm}^2$ or $2 \times 1.5 \text{ mm}^2$ in the screw-plug terminals. The cross section of the protective conductor must at least correspond to the cross-section of the power cable.

For input quantities such as voltage or resistance, a zener diode combination must not be installed.

The "zener diode combination" consists of 2 counter-connected zener diodes and 2 capacitors which are arranged in parallel to the zener diodes.

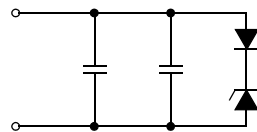

The voltage drop across the zener diodes is 3.9 V. The capacitors cause a flat rise of the load with a recorder-internal current interruption.

⚠ Caution

To protect current measuring points from device-internal interruption of the measuring circuit, install a zener diode combination at the connection terminals of each current circuit. The zener diode combination (Ordering number A421A- see data sheet) is part of the recorder accessories.

1.5 Placing the recording chart

Recording table for roll charts (see Figure 5 and Figure 6)

1. Unlock the recording table: push down the unlocking lever **Eh** (see Figure 5). The recording table swings forward. Remove the recording table.
2. Swing the pressure flap **Pa** open.
3. Insert the chart roll into the chart reservoir **Pm**.
4. Pull the beginning of the chart up to the pin platen and engage the perforation with the pin platen. Observe the parallelity between chart and pin platen!
5. Close the pressure flap **Pa**.
6. Swing the guide flap **Pf** open.
7. Insert the take-up reel **Ar**.
8. Close the guide flap **Pf**.

Note

After inserting the recording table into the recorder the chart winds up automatically onto the take-up reel.

9. Swing the recording table into the chassis until it engages.

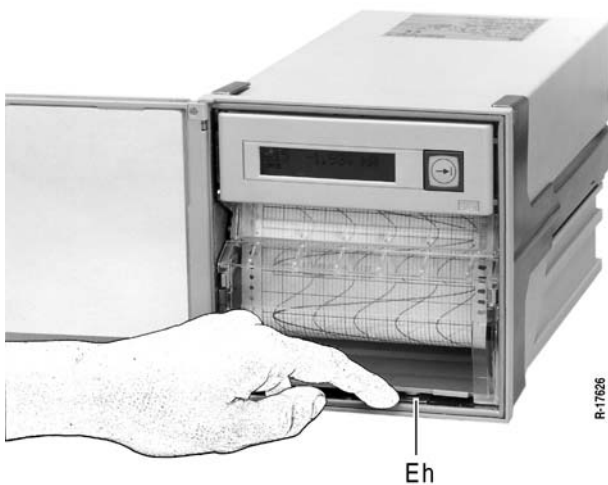

Figure 5 Unlocking recording table

- Ar** Take-up reel
- Ff** Tongue
- Pa** Pressure flap
- Pf** Guide flap

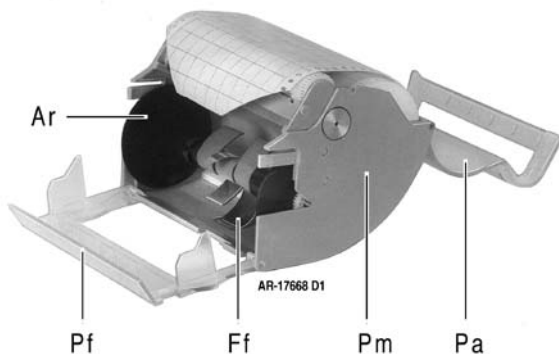

Figure 6 Recording table for roll charts

Recording table for fanfold charts(see Figure 5, Figure 6 a. Figure 7)
For changing the recording table for roll charts to fanfold charts, remove tongue **Ff** and take-up reel **Ar** (see Figure 6).

1. Unlock the recording table: push down the unlocking lever **Eh** (see Figure 5). The recording table swings forward. Remove the recording table.
2. Swing the pressure flap **Pa** open.
3. Insert the fanfold package into the chart reservoir **Pm**.
4. Pull the beginning of the chart up to the pin platen and engage the perforation with the pin platen. Two fanfold layers must lie on the bottom of the deposit. Observe the parallelity between chart and pin platen!
5. Close the pressure flap **Pa**.
6. Swing the guide flap **Pf** open.
7. By turning the pin platen, move the chart forward until 2 fanfold layers are lying on the bottom of the deposit.
8. Close the guide flap **Pf**.
9. Swing the recording table into the chassis until it engages.

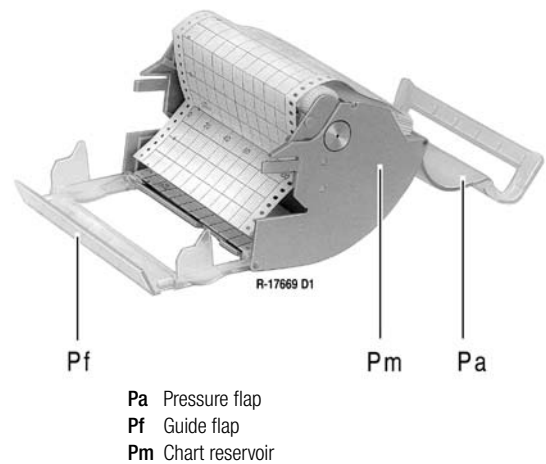

Figure 7 Recording table for fanfold charts

1.6 Placing the color head

Scale version (see Figure 8)

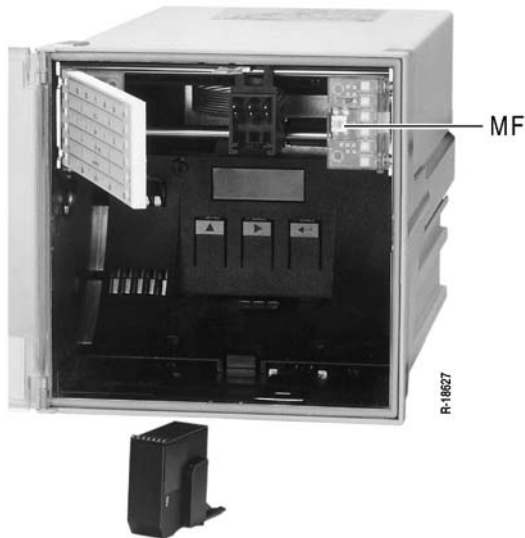

Figure 8 Placing the color head (scale version)

1. Unlock the recording table: push down the unlocking lever **Eh** (see Figure 5). The recording table swings forward.
2. Remove the recording table.
3. Swing up the pointer.
4. Swing the scale open.
5. Press the MF key for approx. 2 s. The pushbutton changes into the park position.
6. Place the color head as shown in Figure 8.
7. Press the MF key. The recorder takes up recording operation.
8. Close the scale.
9. Swing down the pointer.
10. Swing the recording table into the chassis until it engages.

Display version (see Figure 9)

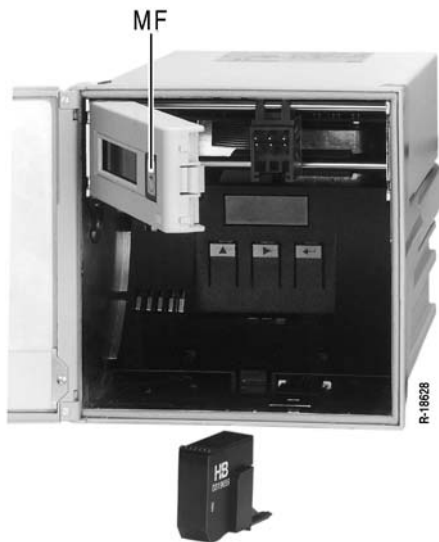

Figure 9 Placing the color head (display version)

1. Unlock the recording table: push down the unlocking lever **Eh** (see Figure 5). The recording table swings forward.
2. Remove the recording table.
3. Press the MF key $\leftarrow \rightarrow$ for approx. 2 s. The measuring system changes into the park position.
4. Swing the display open to the left.
5. Place the color head as shown in Figure 9.
6. Close the display to the right.
7. Press the MF key $\leftarrow \rightarrow$. The recorder takes up recording operation.
8. Swing the recording table into the chassis until it engages.

1.7 Switching the recorder on

Caution

Prior to switching on the power supply it is necessary to make sure that the operating voltage of the device (see rating plate) and the supply voltage correspond to each other.

A line connection switch of sufficient switching capacity, which permits all-pole disconnection of the recorder from the line, must be provided within reach of the mounting site. It must not annul the protective effect of the protective conductor.

1.8 Positioning the recording chart (see Figure 10)

The pushbutton records at a distance of 11.5 mm before the leading edge of the pressure flap.

1. Push back the lower handle rails of the recording table. The recording chart is transported acceleratedly in the flow direction.
2. Let the handle rails go when the desired time line corresponds to the leading edge.

Note

If the time print or the print of the date-time line is activated, after letting go the handle rails the recording chart is transported until the next time print or print of the date-time line can be carried out at the desired position.

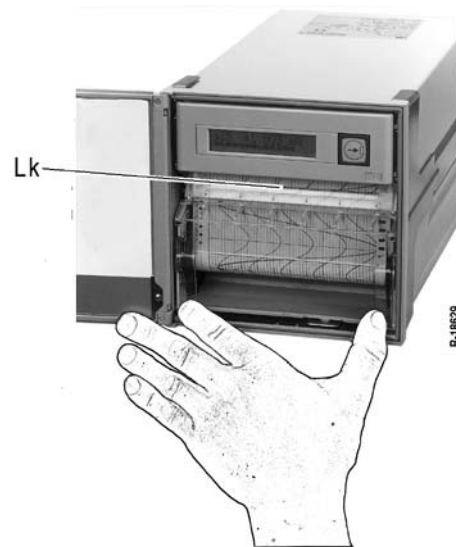

Figure 10 Positioning the recording chart

2 Operation

2.1 Removing the recording chart (see Figure 11)

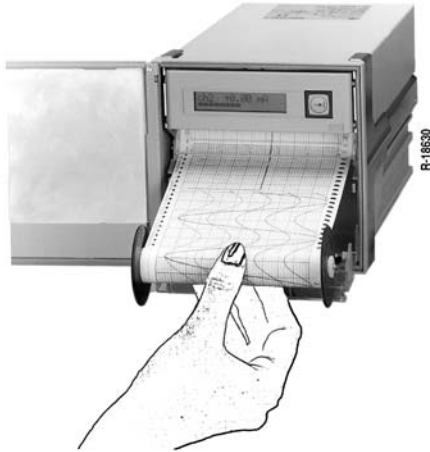

Figure 11 Removing the recording chart

The recording table can remain in the recorder for removing the chart.

Recording table for roll charts

1. Swing the chart guide flap open to the bottom.
2. Remove the take-up reel.
3. If necessary, tear off the chart at the tear-off edge.

Recording table for fanfold charts

1. Swing the chart flap open to the bottom.
2. Remove the recording chart.
3. If necessary, tear off the chart at the folding edge.

Note

Two fanfold layers of the chart must lie in the deposit.

2.2 Removing the recording chart from the take-up reel (see Figure 12)



Figure 12 Removing the recording chart from the take-up reel

1. Turn the flange without driving pinion by 45° and pull it off the take-up reel.
2. Touch the chart as shown in Bild 12 and pull it off the axis.
3. Put the right flange back onto the take-up reel and lock it by turning it by 45°.
4. Insert the take-up reel into the recording table. The driving pinion must be situated at the right.
5. Close the guide flap.

2.3 Changing the chart speed

If the recorder is fitted with the option "Limit monitoring and binary inputs", it can be changed externally between speed 1 and speed 2. In the parameterizing mode, the desired values for speed 1 and speed 2 are selected. Also the binary input with which speed 2 is activated is selected in the parameterizing mode (see parameterizing instructions).

Speed 1 is activated after switching on the recorder. By applying a voltage of 24 V DC between the terminals 901(-) and the terminal assigned to the selected binary input (+) speed 2 is activated.

2.4 Standby function

If the recorder is fitted with the option "Limit monitoring and binary inputs", it can be changed to standby. In the parameterizing mode, a binary input must be selected for switching the standby function. For switching on the standby function a voltage of 24 V DC must be applied between the terminals 901(-) and the terminal assigned to the selected binary input (+).

In the standby mode the speed is switched off. The measured value processing and the limit monitoring are activated.

The standby is annulled by limit violations or by switching off the applied voltage at the binary input. The recorder takes up recording operation.

If the MF key is activated for standby control, the standby function can also be switched on and off via double-clicking this key.

If the recorder is parameterized in a way that the recorder changes to standby when the power supply is applied, the recorder is switched on and off with the help of the MF key.

2.5 Measured value display

In the scale version, the active LED of the left LED column signals the measuring channel displayed by the measuring system. The right active LED signals the scale division assigned to the measuring channel.

In the display version, the measuring channel and the corresponding measured value are displayed alphanumerically.

The following factory setting applies for both versions:
During the cycle time all measuring channels are processed and recorded but only one measuring channel is displayed. After the end of the cycle the display changes to the next measuring channel and so on. If a selected point of measurement is to be displayed continuously, the setting can be carried out as follows with the help of the MF key:

MF key	Cyclic display of all measuring channels enabled for display
< → >	Static display measuring channel 1
< → >	Static display measuring channel 2
< → >	Static display measuring channel 3
< → >	Static display measuring channel 4
< → >	Static display measuring channel 5
< → >	Static display measuring channel 6
< → >	Display of the remaining chart length in m (only in the display version).
< → >	Cyclic display of all measuring channels enabled for display.

Special operating states of the display in the display version

Display Operating states

{CH.}	Static display of the measuring channels
{c h}	Cyclic display of the measuring channels
{CH. ↑...}	Range exceeding (↑ flashes)
{CH. ↓...}	Range undershoot (↓ flashes)
{CH. ?...}	Violation of the limits of the result range
{CH. *...}	Line break
{CH. &...}	Result channel of 2 arithmetically connected channels
{CH. ?...}	Display of the integrated measured value (sum) instead of the measured value (only possible with the balancing activated)
{CH. 10...}	Logarithmic display of the measured value (decimal logarithm)

Special digit formats

For the display of the cumulative value for the balancing function the exponential display is selected.

Example 1

$$\{7.45 E6\} = 7.45 \cdot 10^6 = 7\,450\,000$$

For a logarithmic course of the display range also the exponential display is selected.

Example 2

$$\{7.45 10 6\} = 7.45 \cdot 10^6 = 7\,450\,000$$

The difference between the two displays is that in Example 1 the mantissa goes linearly and in Example 2 it goes logarithmically.

Special operating states of the display when using the standby function

{STANDBY: ACT: DI}	Standby is switched on. The standby was activated via a binary input (parameterization).
{STANDBY: DEL: DI}	Standby is switched on after the delay has elapsed. The standby was activated via a binary input.
{STANDBY: ACT: AUTO}	Standby is switched on. The standby was activated by switching on the power supply (parameterization).

2.6 Balancing function

If the MF key is activated with the balancing function activated, the print of the lines specified during parameterization can be initiated channel-specifically by double-clicking this key. The balancing interval control (internal cyclically or via binary inputs cyclically) is not influenced by that.

Note

The balancing function and the standby function are mutually exclusive.

2.7 End-of-chart signalling

Insert the roll chart or the fanfold chart (see Section "Placing the recording chart").

Display remaining chart length

(only with the display version)

With the help of the MF key, the remaining chart length can be displayed.

MF key	Cyclic display of all measuring channels enabled for display
< → >	Static display measuring channel 1
< → >	Static display measuring channel 2
< → >	Static display measuring channel 3
< → >	Static display measuring channel 4
< → >	Static display measuring channel 5
< → >	Static display measuring channel 6
< → >	Display of the remaining chart length in m (only in the display version)
< → >	Cyclic display of all measuring channels enabled for display.

Additionally, depending on the value of the active speed, the remaining time until the chart change is displayed. The value of the remaining chart length recorded continuously by the recorder is power failure protected. In case of a power failure, the value is written in an F-RAM.

Enter chart length (in the display version)

After a new chart roll or fanfold package was inserted the length of the new chart reservoir is entered as follows:

1. Press the MF key < →|> until the display "Display of the remaining chart length" appears.
2. Remove the recording table.
3. Press < ←|>. $\{L = ? 000\}$ is displayed. The last digit of the numerical value flashes.
4. Enter the chart length with the keys < ▶> and < ▲>.

In the parameterizing mode, the assignment of the end-of-chart signalling to the contact output is made in the main menu item "System" under the parameter "chart end DO x". Depending on the speed, the end-of-chart signalling is issued 2 hours before the chart end.

Enter chart length (in the scale version)

If an assignment of the end-of-chart signalling to the contact output was made in the parameterizing mode in the main menu item "S Y S" under the parameter "P A. O U t", the remaining chart length is displayed after removing the recording table. The entry of the chart length (after placing a new roll chart or fanfold package) is made in the parameterizing mode under the main menu item "S P. F n C" in the parameter "P A. L E n".

3 Parameterizing

The POINTAX 6000M is parameterized via an operating panel in the recorder or from the PC via the RS 485 interface. The program PARATOOL P6000M is available for the parameterization of the recorder via this interface (see data sheet).

If access to the parameter level is blocked because a password was defined, the parameter values can be read only:

1. Press \leftarrow . The display shows "Password 0000". The last digit of the parameter value flashes.
2. With the keys \rightarrow and \uparrow enter password 9999.
3. Main menu items and parameters are selected. The parameter values are displayed.

4 Reconfiguration

4.1 Firmware update (removing the electronic unit)

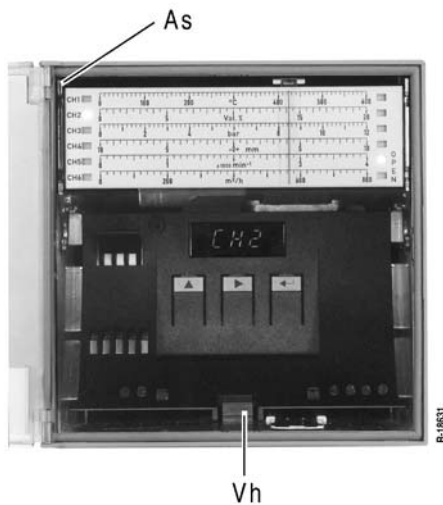

Figure 13 Removing the electronic unit

1. Loosen the arresting screw **As** (see Figure 13) and pull the system carrier approx. 2 cm forward.
2. Lift the interlocking lever **Vh** (see Figure 13) and simultaneously pull forward the unit.
3. Pull off the plug to the measuring system.
4. Remove the electronic unit from the case (see Figure 14).
5. Replace the EPROM.
6. Carry out the remounting reversely.

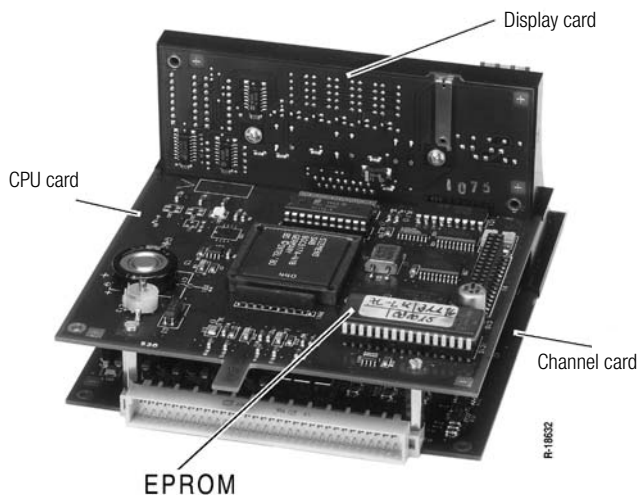

Figure 14 Electronic unit removed (view from behind)

4.2 Replacing scales (see Figure 15)

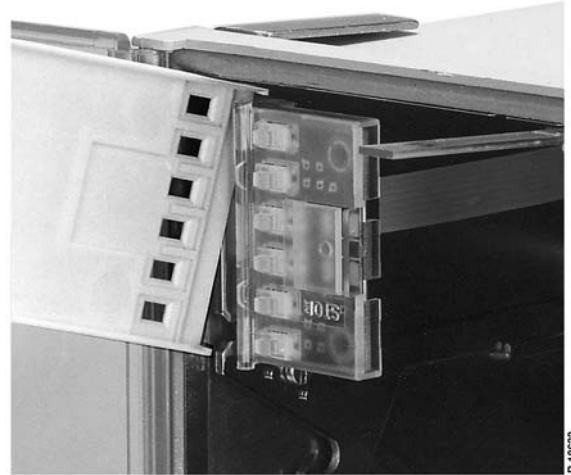

Figure 15 Replacing scales

1. Swing up the pointer.
2. Swing the scale open by 90°.
3. Slightly bend down the flange of the U-shaped scale and disengage the hinge.
4. Remove the scale to the front.
5. Remount the scale reversely.
6. Close the scale to the right and swing down the pointer.
7. Check measuring system zero with beginning of the scale. Remove the recording table.

Press \leftarrow .

{SYS} is displayed.

Press \rightarrow several times until {SP.FnC} is displayed.

Press \leftarrow .

{Si.tYP} is displayed.

Press \rightarrow several times until {Sc.oFS} is displayed.

Press \leftarrow . The measuring system goes to a position below electrical zero. In the display e.g. {0028} is displayed flashing.

Press \rightarrow .

The pointer moves to the right.

Press \rightarrow until the pointer is aligned to the initial value of the division.

Press \leftarrow .

{Sc.oFS} is displayed.

Press \uparrow .

{SP.FnC} is displayed.

Press \uparrow .

{SAVE?} is displayed.

Press \leftarrow . The calibration data are stored in the EEPROM. Insert the recording table.

4.3 Replacing the label for measuring points

(see Figure 16 and Figure 17)

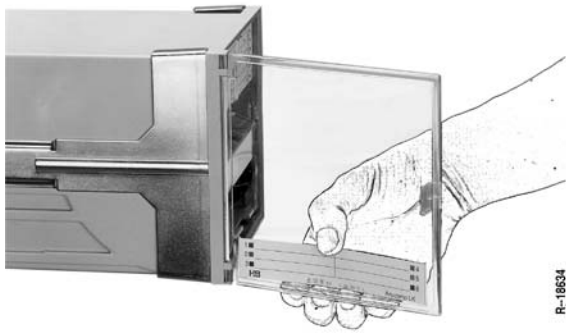

Figure 16 Replacing the label for measuring points at a door of molded material

1. Pull the flexible label for measuring points from its holder.
2. Insert the new label for measuring points.

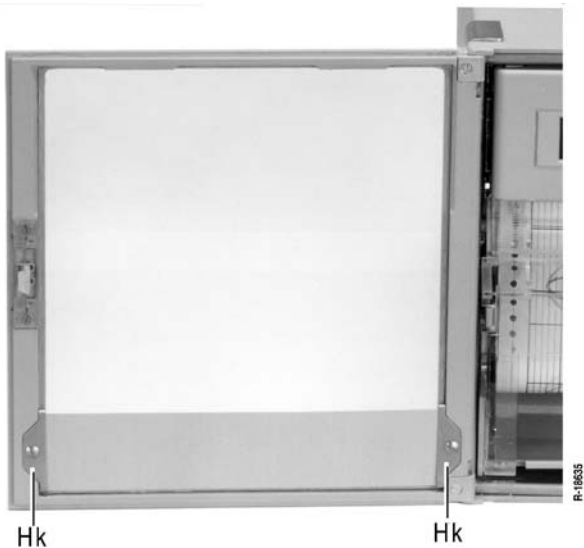

Figure 17 Replacing the label for measuring points at a door with metal frame

1. Unscrew the holding cramps **Hk**.
2. Remove the label for measuring points.
3. Insert the new label for measuring points.
4. Tighten the holding cramps **Hk**.

4.4 Replacing the case doors (Figure 18 and Figure 19)

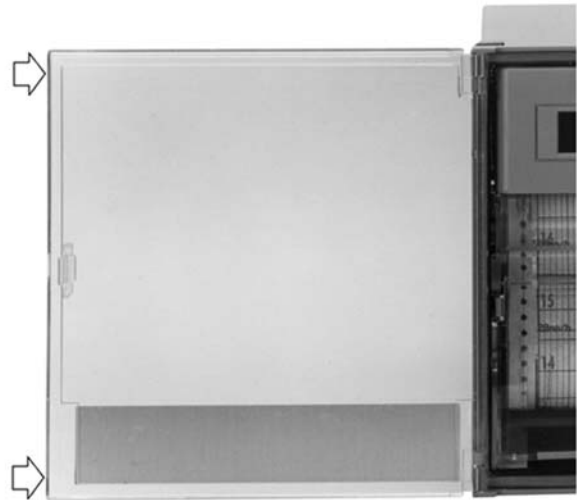

Figure 18 Replacing a door of molded material

1. Open the case door by 180°.
2. Push against the narrow cant of the door, first at the top, then at the bottom (see Figure 18) until the door hinge is disengaged.
3. Hang the new door on its hinges (at 180° beam width).
4. Push on the face of the door hinge, first at the bottom, then at the top.

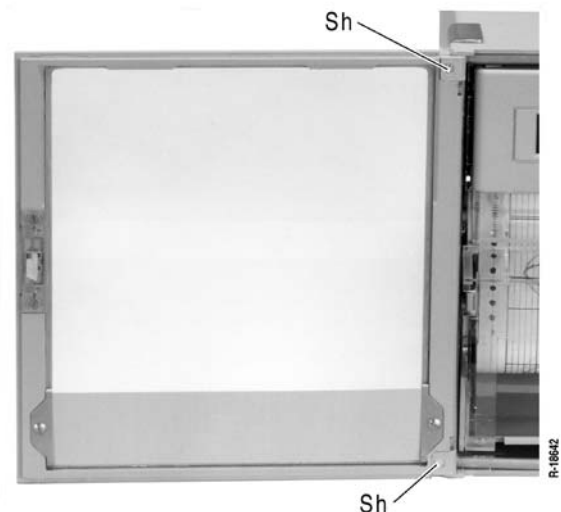

Figure 19 Replacing a door with metal frame

1. Loosen the screws at the top and at the bottom hinge and remove them.
2. Remove the door.
3. Insert the new door.
4. Place the screws at the top and at the bottom hinge again and tighten them.

5 Maintenance

5.1 Fuse replacement (see Figure 20)

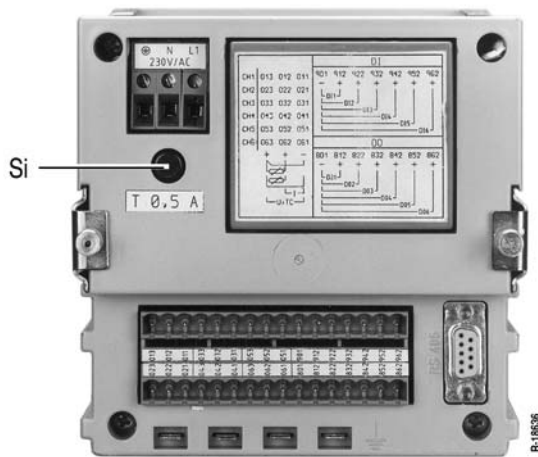

Figure 20 Replacing fuse *Si*

Caution

It must be observed that the replacement fuses are of the specified type and the specified nominal current rating only. The use of mended fuses or shorting of the fuse holder is not permissible.

Live parts can be exposed when opening covers or removing parts, except where this is possible manually. Also connection points may be live.

1. Unscrew fuse holder.
2. Replace the fuse **Si**.
3. Screw in fuse holder again.

Fuse values

230 V	T 0.5 A
115 V	T 0.5 A
24 V	M 1.6 E

6 Technical data

Applied rules and standards

A) International standards

IEC 484	DIN 43782	Potentiometric recorders
IEC 61010-1	DIN EN 61010-1	Electrical safety (test voltages)
IEC 664	VDE 0110	Insulation group
IEC 68-2-6	DIN IEC 68-2-6	Mechanical stress (vibrations)
IEC 68-2-27	DIN IEC 68-2-27	Mechanical stress (shock)
IEC 60529	VDE 0470-1	Degree of protection of the case
DIN EN 61326-1	VDE 0843-20-1	EMC Requirements
IEC 721-3-3	DIN IEC 721-3-3	Climatic environmental conditions
IEC 742	DIN EN 60742	Classification VDE 0551 safety transformers

B) German standards

DIN 43802	Scales
DIN 16234	Recording chart
DIN 43831	Cases

Symbols and their meaning

Symbol	Meaning
X1n / X1	Lower range limit nominal range / lower range limit
X2n / X2	Upper range limit nominal range / upper range limit
X2n – X1n / X2 – X1	Range span nominal range / range span

Analog inputs, nominal ranges

DC current	0...20 mA; Ri = 50 Ω 4...20 mA; Ri = 50 Ω ± 2.5 mA; Ri = 50 Ω ± 5 mA; Ri = 50 Ω ± 20 mA; Ri = 50 Ω
DC voltage	0 ... 25 mV; Ri ≥ 2 MΩ ± 25 mV; Ri ≥ 2 MΩ 0 ... 100 mV; Ri ≥ 2 MΩ ± 100 mV; Ri ≥ 2 MΩ 0 ... 500 mV; Ri ≥ 2 MΩ ± 500 mV; Ri ≥ 2 MΩ 0 ... 2.5 V; Ri ≥ 200 kΩ ± 2.5 V; Ri ≥ 200 kΩ 0 ... 5.0 V; Ri ≥ 200 kΩ ± 5.0 V; Ri ≥ 200 kΩ ± 10 V; Ri ≥ 200 kΩ ± 20 V; Ri ≥ 200 kΩ
Thermocouples Ri ≥ 2 MΩ	Type T –270 ... +400 °C Type U –200 ... +600 °C Type L –200 ... +900 °C Type E –270 ... +1000 °C Type J –210 ... +1200 °C Type K –270 ... +1400 °C Type S –50 ... +1769 °C
Thermocouples, Ri ≥ 2 MΩ	Type R –50... +1769 °C Type B 0 ... +1820 °C Type N –20 ... +1300 °C Cold junction compensation internally or externally parameterizable
Resistance thermometer Pt 100	–50 ... +150 °C; –50 ... +500 °C; –200 ... +850 °C
With 2-wire connection	Line resistance 40 Ω max.
With 3-wire connection	Line resistance 80 Ω max.

Analog inputs, measuring ranges

Lower range limit	parameterizable from X1n ... X1n + 0.8 (X2n – X1n) and
Range span	parameterizable from 0.2 (X2n – X1n) ... (X2n – X1n).
Deadband	0.25 % of the range span
Setting time	1 s
Load cycle time	for all channels 3 ... 360 s selectable
Attenuation of the meas. value	with low-pass filter of 1st order;
Time constant	0 ... 60 s per measuring channel, parameterizable.
Root-extract. funct.	can be parameterized with DC current and DC voltage measuring ranges.
User-specific linearization	can be parameterized with DC current and DC voltage measuring ranges.

Reference conditions

Ambient temperature	25 °C ± 1 K
Relative humidity	45 ... 75 %
Auxiliary voltage	Hn ± 2 %, nominal frequency ± 2 %
Mounting position	Front upright ± 2°
Warm-up time	30 min

Accuracy

Deviation in acc. with DIN IEC 484	Class 0.5 referred to nominal range
With displacement of lower range limit and/or upper range limit additionally	± (0.1 % × $\frac{X2n - X1n}{X2 - X1} - 0.1$)
With internal cold junction compensation	± 4 K additionally

Variations

Temperature	0.2 % / 10 K, additionally 0.1 % / 10 K with conn. to thermocouple
Humidity	Note influence on recording chart in acc. with DIN 16234.
Auxiliary voltage Hn	0.1 % at 24 V DC/AC ± 20 % 0.1 % at 24 V AC +10 % / –15 % 0.1 % at 115 V AC +10 % / –15 % 0.1 % at 230 V AC +10 % / –15 %
AC interference voltages (see permissible interference voltages)	0.5 % of the range span
Magnetic field of ext. origin 0.5 mT	0.5 % of the range span
Mechanical stress in acc. with DIN IEC 68-2-6/27	During and after the effect ± 0.5 % of the range span
Transport Impact: 30 g/18 ms Vibration: 2 g/5 ... 150 Hz	
in function Vibration: 0.5 g/± 0.04 mm/ 5...150 Hz/3 × 2 cycles	

Binary inputs

Number	6 (DI 1 ... DI 6)
Auxiliary voltage	20 ... <u>24</u> ... 30 V DC
Input current	6 mA
H signal	20 ... 30 V
L signal	0 ... 1.3 V

Relay outputs

6 potential-free relay contacts (roots connected to each other)
Contact load: 30 V / 100 mA
14 additional relays available via external I/O converter.

Real-time clock

Function maintained in the case of power failure: 5 days (capac.).

Options

External speed change

It is possible to switch between speed 1 and 2 and to switch the speed off, each via a freely selectable binary input.

Standby function

The standby function is activated via a freely selectable binary input. Internal deactivation via limit monitoring is possible.

Event markers

4 markers are possible. Recording at approx. 2 %, 5 %, 95 % and 98 % of the recording width.

Externally controlled recording

Recording of externally controlled channels.

10 event markers

Usable (without measuring value recording) via external I/O converter (also see trend recording).

Balancing

Balancing can be selected for each measuring channel. The external control of the balancing interval is via a freely selectable binary input.

End-of-chart signalling

With speeds of ≥ 120 mm/h, 2 hours before the chart runs out. With speeds of < 120 mm/h, at least 8 hours before the chart runs out. Signalling is via a relay contact which can be freely assigned. When changing the recording chart, enter the length of the chart roll into the recorder.

Limit monitoring

2 limits per channel for monitoring the absolute value. 6 internal relays can be freely assigned to the limits. Hysteresis 2 % of the range span (X2 – X1)

Display

Scale version

Scale

1 to 6 divisions

Type size at number of divisions:

Divisions	1	2	3	4	5	6
Type size (mm)	4	4	4	2	2	2

Channel display

by vertical LED column on the right side of the scale

Assignment scales to channel

by vertical LED column on the left side of the scale

Display and control panel (behind the recording table)

Display (only for parameterization) 5-digit 7-segment display

Digit size 4 × 7 mm

Operation with 3 keys

Display version

LC display (backlit)

16-digit, digit size 3.1 × 5.5 mm

in the operating mode it serves the display of measuring point number (1-digit), measuring value (5-digit), unit of mass (7-digit), limit status

in the parameterizing mode it serves the display of the parameters and parameter values

Recording

Colors

Color sequence in acc. with DIN 43838 violet, red, black, green, blue, brown

Channel 1 violet

Channel 2 red

Channel 3 black

Channel 4 green

Channel 5 blue

Channel 6 brown

or freely assignable to the channels

Last point visible from the front

Color reservoir $\geq 1 \times 10^6$ points per color

Trend recording

The measured value recording is carried out in the form of a point line with equidistant point space.

Operating modes

Cyclic operation – Processing all channels

Recording:

all channels are updated during the cycle time

Measured value display:

a measuring channel switches continuously or channel-wise from cycle to cycle.

Externally controlled

Recording:

the externally controlled channels are recorded, recording start of 0 ... 30 s can be delayed

Measured value display:

switches channel-wise from cycle to cycle.

Option required

Cyclic operation – Processing one channel

Recording and measured value display:

the displayed channel is updated during the cycle time.

DI 1 ... DI 6 signals the measuring channel connected through.

Option required

Event recorder for 10 events

Recording:

Start, duration and end of the event are recorded in the form of an open rectangle.

Display in the display version:

last event as plain text message

I/O converter required

Text print

only possible with chart speed ≤ 240 mm/h

Type size approx. 1.5 × 2 mm

Extent of the text print:

1. Ten text lines, each text line optionally with up to 32 characters up to 30 characters and time print up to 24 characters and time/date print. Initiated cyclically, in parameterizable time intervals or depending on events by internal limits or externally controlled (binary inputs).
2. Print chart speed, date and time. Initiated by switching on the recorder and by changing the speed.
3. Print of current measured values Initiated cyclically, in parameterizable time intervals or depending on events by internal/external control.
4. Print of triple lines assigned to measuring points. First line: Scaling line with channel marking and print of the unit of mass. Second line: Measuring-point-specific text with up to 54 characters. Third line: Limit markings.
5. Print of the balancing table consisting of: Comment line Start and end time of the balancing interval Min. / max. value during the balancing interval Average and cumulative value of the balancing interval
6. Lists of all active parameters Initiated manually in the parameterizing mode.

Chart roll speed

Speed parameterizable in mm/h	0/2.5/5/10/20/30/40/60/120/240/300/600/1200 to be switched over and off externally (option)
Chart roll	32 m roll chart or 16 m fanfold chart
Visible diagram length	60 mm
Print span	100 mm (chart span 120 mm, DIN 16230)
Chart intake (for roll chart)	via automatic chart take-up device (daily tear-off or take-up of the 32 m possible)

Auxiliary voltage

UC power supply

24 V DC \pm 20 %

24 V AC +10 %, -15 %

Power consumption at max. fitting approx. 15 W / 21 VA

AC power supply

24/115/230 V AC +10 %, -15 %

Frequency range 47.5 ... 63 Hz

Power consumption at max. fitting approx. 15 W / 21 VA

RS 485 interface

- For parameterization
- Coupling to higher order systems for bidirectional data transfer.
The data protocol follows the PROFIBUS standard.

Climatic suitability

Ambient temperature	0 ... 25 ... 50 °C
Transport and storage temperature	-40 ... +70 °C
Relative humidity (device in function)	\leq 75 % annual average, max. \leq 85 %, prevent dewing
Climatic class	3K3 in acc. with IEC 721-3-3

Electrical safety

Test in acc. with DIN EN 61010-1 (Classification VDE 0411)

and/or IEC 61010-1

Protection class I

Measuring category

III at line input

II at inputs

Degree of pollution

2 in the device and at the connecting terminals

Test voltage

3.75 kV measuring channels to power supply

2.20 kV protective conductor to power supply

Functional extra low voltage with protective isolation (PELV)

Between power input – measuring channels, control leads, interface cables in acc. with VDE 0100-410 and VDE 0106-101

Electromagnetic compatibility

The protection goals of the EMC directive 2014/30/EU as to radio interference suppression and as to immunity to interference in accordance with DIN EN 61326-1 are complied with.

Factory settings

Scale with a division of 0 ... 100

It is supplied when no scale division is specified in the scale device order.

Parameter presettings

If no individual parameterization is specified in the recorder order, the POINTAX 6000M is supplied with the following parameter presettings:

All measuring channels with the measuring range 0 ... 20 mA

Speed 1: 20 mm/h

Speed 2: 120 mm/h

The limits are set to end values (0 and 20 mA).

Attenuation of the measured value, zoom, print and limit functions are deactivated.

No password is defined.

This parameter presetting can be initialized again independently from the currently set parameterization.

Connection, case and installation

Electrical connections

Degree of protection IP 20

Screw-plug terminals for measuring inputs, control inputs and limit value relay outputs.

Max. wire cross section $2 \times 1 \text{ mm}^2$

Screw terminals for line connection

Max. wire cross section $1 \times 4 \text{ mm}^2$ or $2 \times 1.5 \text{ mm}^2$

RS 485 interface via 9-pole SUB D plug

Case

Molded material for installation in panels or mechanical grids (see dimensional drawing for dimensions)

Degree of protection of the case in acc. with EN 60529

Front (including door) IP 54

Back IP 20

Color of the case

Silica-gray in acc. with RAL 7032

Door of the case

Metal frame (RAL 7032) with mineral glass or molded material

Fastening of the case

with 2 fasteners (optionally for installation in panel or mechanical grid) for a maximum grid width of 40 mm, centering angle brackets are required for installation in mechanical grids (Ordering number A416A)

Position of use

Inclined to the side [-30° ... 0 ... $+30^\circ$], inclined to the rear 20° , inclined to the front 20°

Mounting distance

horizontal or vertical 0 mm, it must be possible to open the door of the case by 100°

Weight approx. 3.2 kg

7 Packing

The fiber pen inserts must be removed before the recorder is transported.

If the original packaging material is no longer available, wrap the recorder in air-cushion foil or corrugated paper and pack it in a sufficiently large crate which is lined with shock-absorbing material (foam rubber or similar material). The thickness of the padding must be matched to the weight of the device and the type of packaging. The crate must be marked "Fragile".

When shipped overseas, air-tight welding of the recorder into a 0.2 mm thick polyethylene foil which contains a drying agent is additionally required. The quantity of the drying agent is to be chosen in line with the packaging volume and the expected duration of the transport (at least 3 months). The crate must additionally be lined with a layer of double bituminous paper.

8 Returns and Environmentally Sound Disposal

The instrument is a category 9 product (monitoring and control instrument) in accordance with ElektroG (German electrical and electronic device law). This device is subject to the RoHS directive. Furthermore, we make reference to the fact that the current status in this regard can be accessed on the Internet at www.gossenmetrawatt.com by entering the search term WEEE.

We identify our electrical and electronic devices in accordance with WEEE 2012/19/EU and ElektroG using the symbol shown at the right per DIN EN 50419.



These devices may not be disposed of with the trash. Please contact our service department regarding the return of old devices (see address in Section 9).

9 Repair and Replacement Parts Service Calibration Center* and Rental Instrument Service

If required please contact:

GMC-I Service GmbH
Service Center
Beuthener Straße 41
90471 Nuremberg, Germany
Phone: +49 911 817718-0
Fax: +49 911 817718-253
e-mail: service@gossenmetrawatt.com
www.gmci-service.com

This address is only valid in Germany. Please contact our representatives or subsidiaries for service in other countries.

* DAkkS calibration laboratory for electrical quantities, registration no. D-K-15080-01-01, accredited per DIN EN ISO/IEC 17025
Accredited quantities: direct voltage, direct current value, direct current resistance, alternating voltage, alternating current value, AC active power, AC apparent power, DC power, capacitance, frequency and temperature

10 Product Support

If required please contact:

GMC-I Messtechnik GmbH
Product Support Hotline Industry
Phone: +49 911 8602-500
Fax: +49 911 8602-340
e-mail: support.industrie@gossenmetrawatt.com

Edited in Germany • Subject to change without notice • PDF version available on the Internet

 **GOSSEN METRAWATT**

GMC-I Messtechnik GmbH
Südwestpark 15
90449 Nürnberg, Germany

Phone: +49-911-8602-111
Fax: +49 911 8602-777
e-mail: info@gossenmetrawatt.com
www.gossenmetrawatt.com